

Homework: #2, Class #2
Discrete Mathematics (Course Number: MTH-129-51)
Prof. G. Safko
Due: Class #3

Page 41: 9, 10, 23, 40

(For #40, assume Socko is telling the truth. By the problem statement, all the men are lying except for one. Try to contradict Socko's statement, find out who is telling the truth, who is lying and then determine the guilty criminal)

In addition:

1) Prove using truth tables that $p \text{ NAND } q \equiv \sim(p \wedge q)$

2) Prove using truth tables that $p \text{ NOR } q \equiv \sim(p \vee q)$

3) Give a formal proof of the following tautology using the CP rule

$$\sim(A \wedge B) \wedge (B \vee C) \wedge (C \rightarrow D) \rightarrow (A \rightarrow D)$$

4) Given the following circuit:

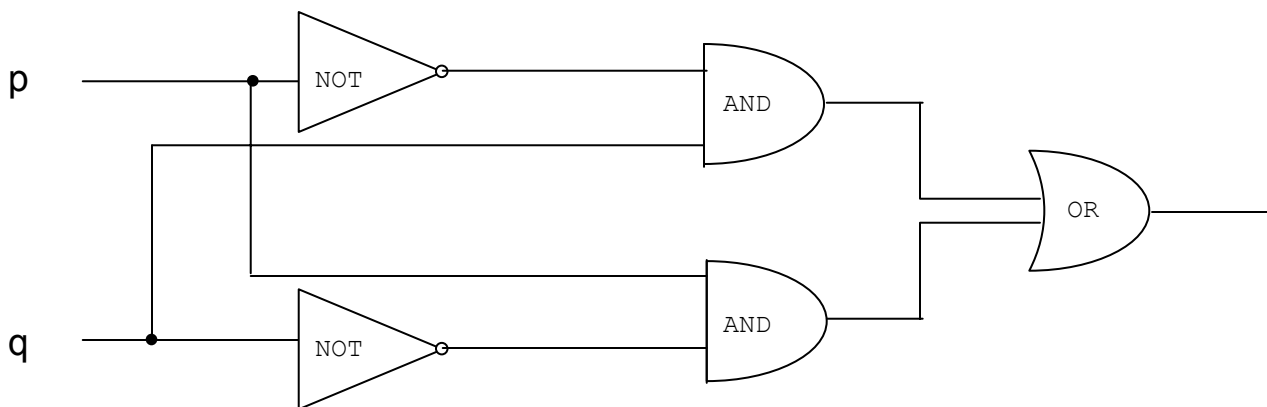

- Convert its input and outputs into a truth table
- Show that this circuit is exactly the circuit for XOR (Exclusive OR, denoted by \oplus)